

# ALP TEX

## Probes For Fine Pitch Connections

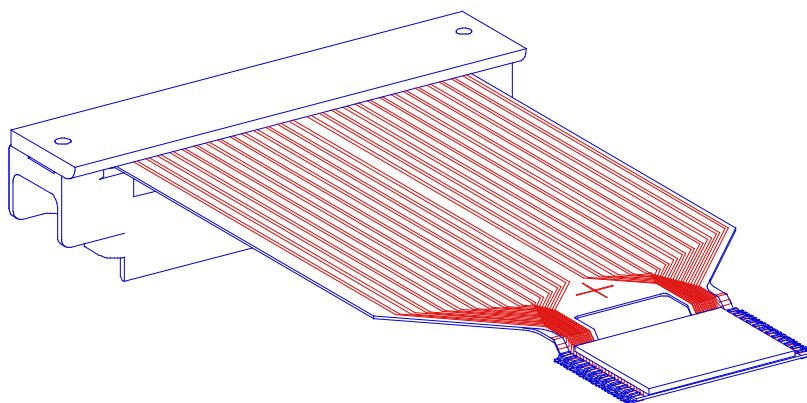

### TSOP FlexProbes 0,50mm (.0197") Pitch

# TSOP FlexProbes 0,50mm (.0197") Pitch

## Data/Application Sheets

ALPTEX Part Number	Description
923706	Standard Pinout, "Hermi" Connector, Direct Solder Type, 32/40/48 Lead
923707	Standard Pinout, "Hermi" Connector, Socket Type, 40/48 Lead
923710	Standard Pinout, Socket Connector, Socket Type, 40/48/56 Lead
923712	Standard Pinout, Socket Connector, Direct Solder Type, 32/40/48/56 Lead
923723	Reverse Pinout, "Hermi" Connector, Socket Type, 40/48 Lead
923724	Reverse Pinout, "Hermi" Connector, Socket Type, 40/48/56 Lead

.pdf files are also available for the following:

- 0,8mm (.0315") Pitch SSOP FlexProbes...SSOP\_FP.pdf
- 1,27mm (.050") Pitch PSOP FlexProbes...PSOP\_FP.pdf
- 1,27mm (.050") Pitch PLCC FlexProbes...PLCC\_FP.pdf
- 0,75mm (.0295") Pitch microBGA FlexProbes...mBGA\_FP.pdf
- FlexProbe Extenders...EXTENDFP.pdf

# TSOP FlexProbe (Direct Solder)

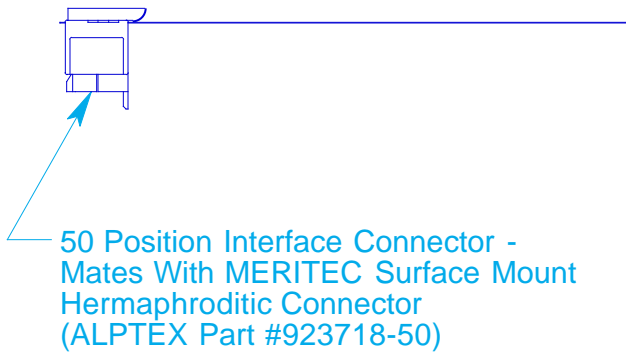
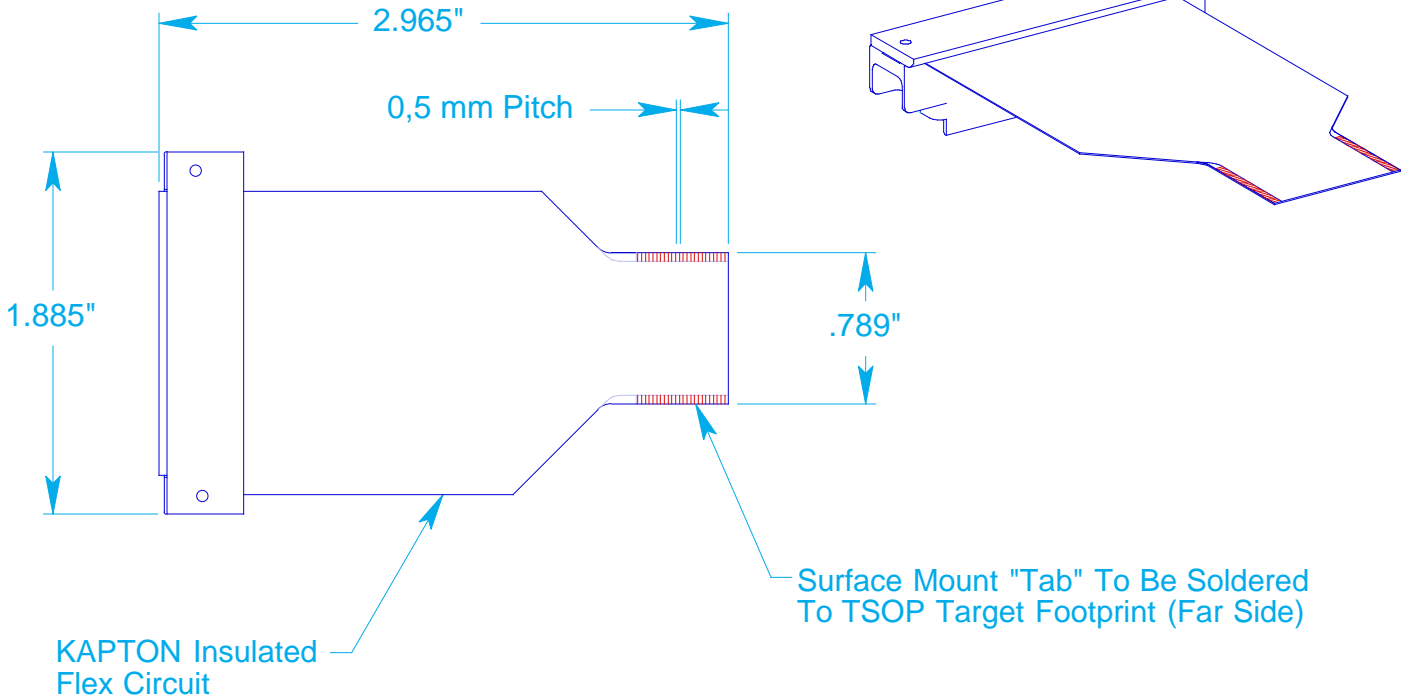

ALPTEx		
PACKAGE	# LEADS	PART NUMBER
TSOP	32	923706-32
	40	923706-40
	48	923706-48

## FEATURES:

- THE MOST FLEXIBLE "TARGET" INTERCONNECT AVAILABLE...MINIMIZES PHYSICAL STRAIN ON THE TARGET PADS.
- A UNIQUE SOLUTION FOR CONNECTING DIRECTLY TO YOUR P. C. BOARD.
- REFLOW SOLDERS TO STANDARD TSOP PAD PATTERN.
- ELIMINATES NEED TO ALTER P. C. BOARD BETWEEN DEVELOPMENT AND PRODUCTION PHASES.
- COMPACT LENGTH VIRTUALLY ELIMINATES CROSSTALK / EMI PROBLEMS.
- MERITEC HERMAPHRODITIC CONNECTOR PROVIDES A DEPENDABLE AND COMPACT INTERFACE FOR YOUR TEST / EMULATION CIRCUITRY.
- MADE ENTIRELY IN THE U.S.A.
- FLEXPROBES FOR EMULATING OTHER POPULAR COMPONENT PACKAGES ARE ALSO AVAILABLE...CONSULT FACTORY.

**ALPTEx** Incorporated  
P.O. Box 476  
Orwell, Ohio 44076  
(440)437-5570 • (440)437-5571 FAX  
[www.alptex.com](http://www.alptex.com)

ALL STATEMENTS, SPECIFICATIONS AND TECHNICAL INFORMATION ON THIS DATA SHEET ARE SUBJECT TO CHANGE AT ANY TIME WITHOUT NOTICE.

# TSOP FlexProbe Application Data

ALPTEX Part Number 923706-XX  
(Direct Solder)

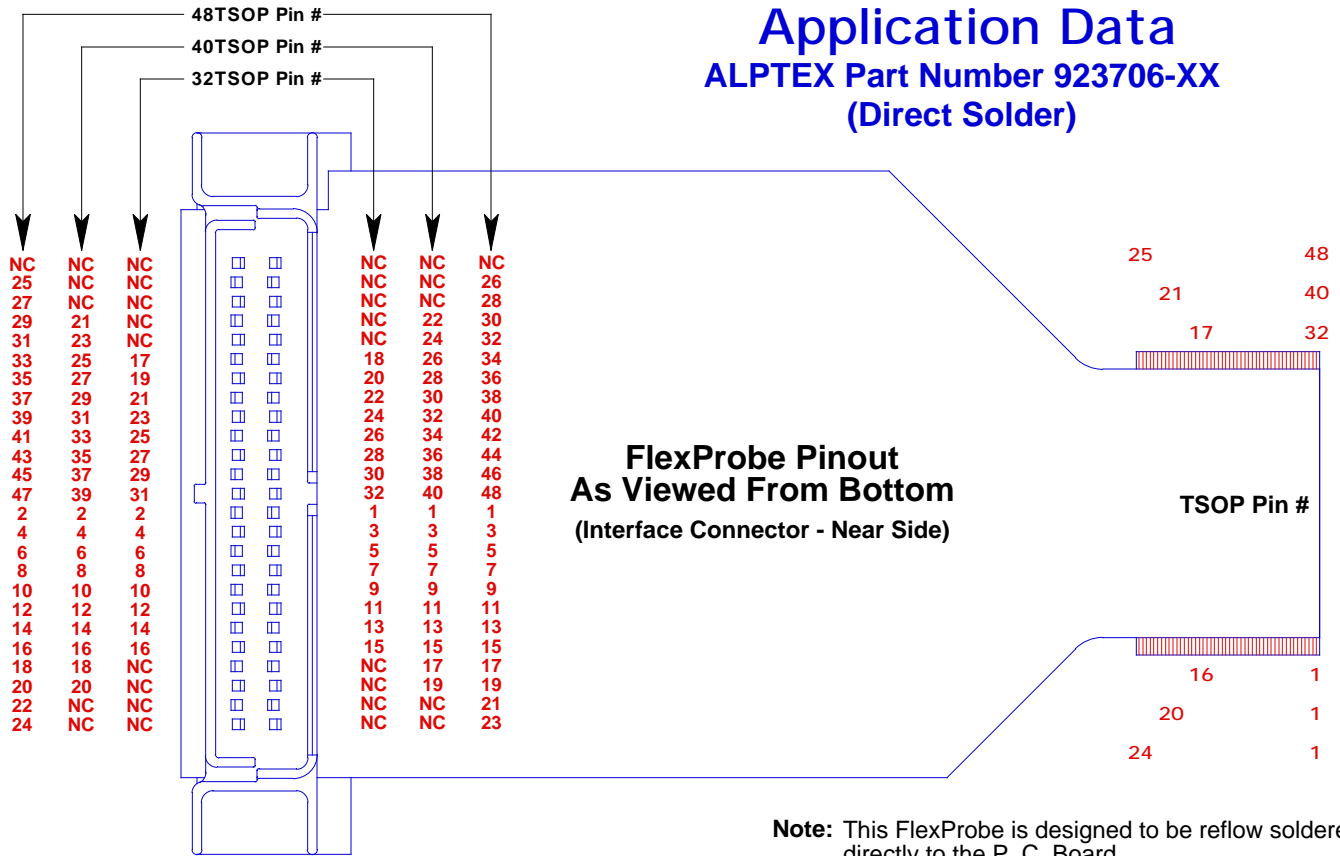

**Note:** This FlexProbe is designed to be reflow soldered directly to the P. C. Board. It is not intended for use with sockets.

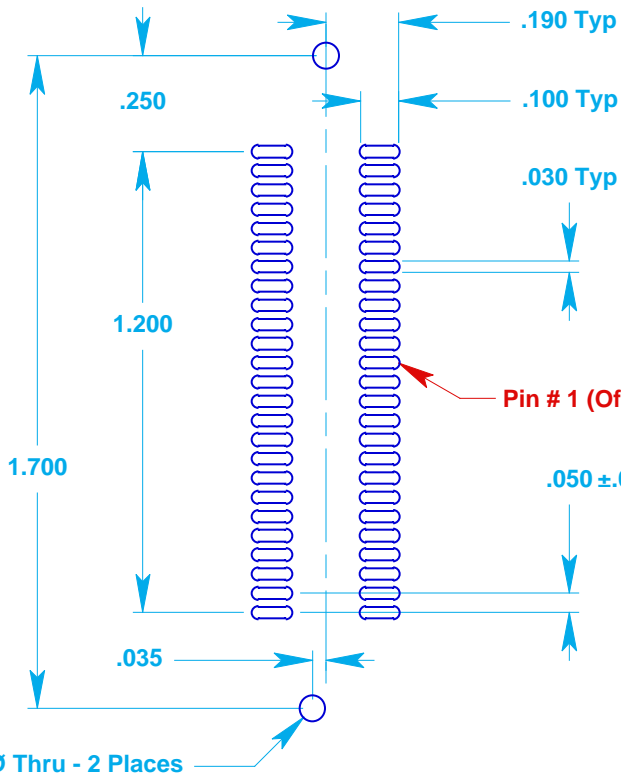

**P C Board Pad Pattern  
For Mating MERITEC Connector  
ALPTEX Part #923718-50  
(Solder Pads - Near Side)**

**ALP  
TEX** Incorporated  
P.O. Box 476  
Orwell, Ohio 44076  
(440)437-5570 • (440)437-5571 FAX  
[www.alptex.com](http://www.alptex.com)

ALL STATEMENTS, SPECIFICATIONS AND TECHNICAL INFORMATION ON THIS DATA SHEET ARE SUBJECT TO CHANGE AT ANY TIME WITHOUT NOTICE.

# TSOP FlexProbe

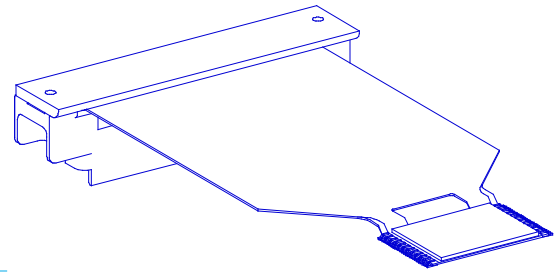
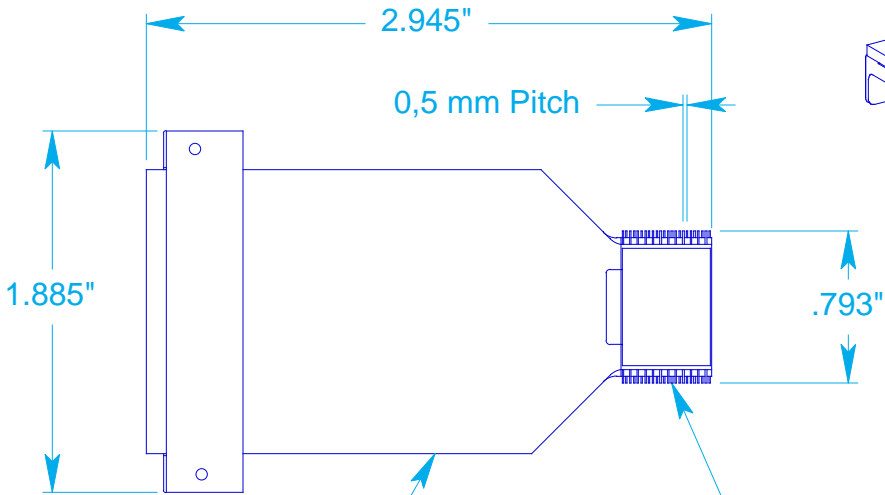

KAPTON Insulated Flex Circuit

TSOP Target Connector - Mates With MERITEC TSOP Socket #980020-XX-XX (ALPTEX Part #923719 or #923720)



50 Position Interface Connector - Mates With MERITEC Surface Mount Hermaphroditic Connector (ALPTEX Part #923718-50)

ALPTEX		
PACKAGE	# LEADS	PART NUMBER
TSOP	40	923707-40
	48	923707-48

## FEATURES:

- THE MOST FLEXIBLE "TARGET" INTERCONNECT AVAILABLE...MINIMIZES PHYSICAL STRAIN ON THE SOCKET.
- A UNIQUE SOLUTION FOR CONNECTING TO MERITEC TSOP SOCKETS.
- FITS INTO SOCKET LIKE A COMPONENT PACKAGE.
- UTILIZES THE MERITEC SOCKET'S "POSITIVE LOCK" FEATURE TO MAINTAIN A SECURE CONNECTION DURING USE.
- SPRING TEMPER NICKEL-SILVER CONTACTS EXCEED INDUSTRY COMPONENT LEAD REQUIREMENTS.
- COMPACT LENGTH VIRTUALLY ELIMINATES CROSSTALK / EMI PROBLEMS.
- MERITEC HERMAPHRODITIC CONNECTOR PROVIDES A DEPENDABLE AND COMPACT INTERFACE FOR YOUR TEST / EMULATION CIRCUITRY.
- MADE ENTIRELY IN THE U.S.A.
- FLEXPROBES FOR EMULATING OTHER POPULAR COMPONENT PACKAGES ARE ALSO AVAILABLE...CONSULT FACTORY.

**ALPTEX** Incorporated  
 P.O. Box 476  
 Orwell, Ohio 44076  
 (440)437-5570 • (440)437-5571 FAX  
[www.alptex.com](http://www.alptex.com)

ALL STATEMENTS, SPECIFICATIONS AND TECHNICAL INFORMATION ON THIS DATA SHEET ARE SUBJECT TO CHANGE AT ANY TIME WITHOUT NOTICE.

CONTENTS

APP DATA

# TSOP FlexProbe Application Data

## ALPTEX Part Number 923707-XX

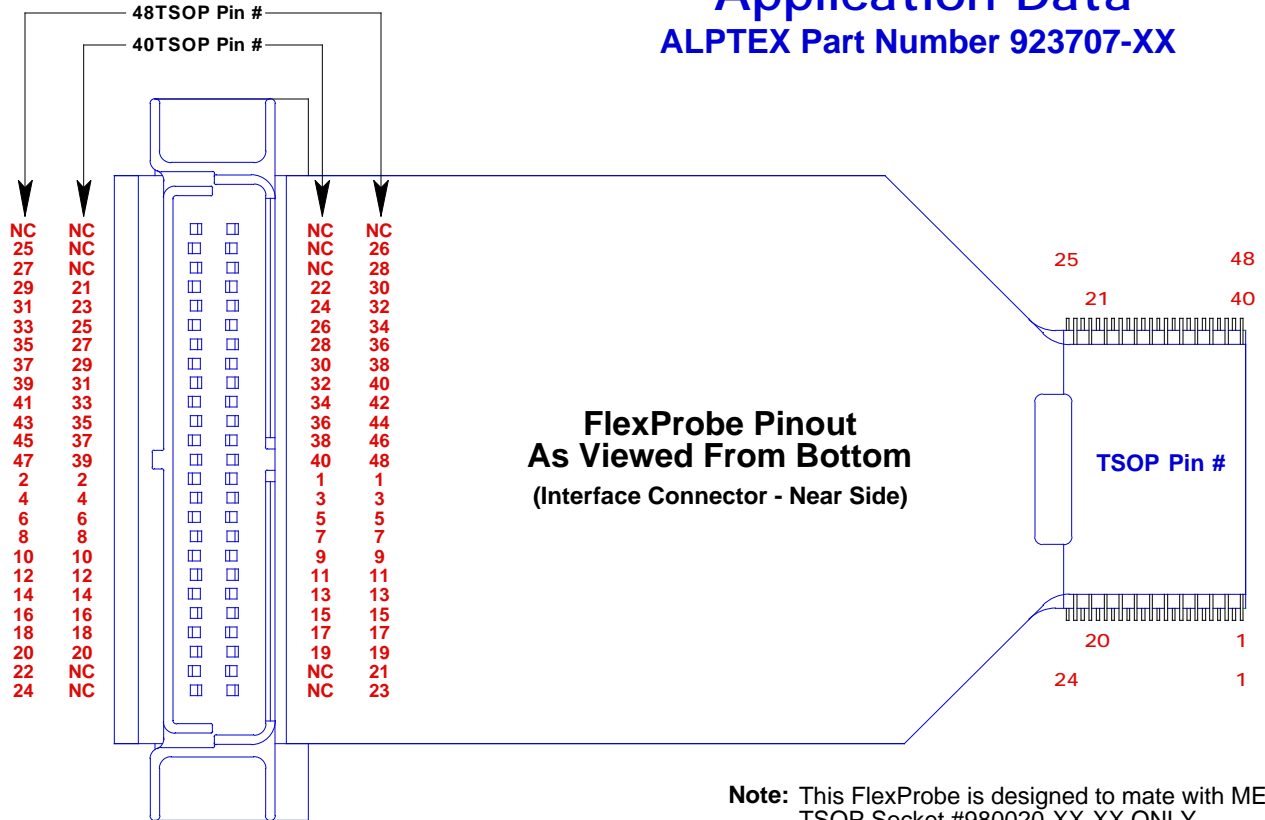

**Note:** This FlexProbe is designed to mate with MERITEC TSOP Socket #980020-XX-XX ONLY. It is not intended for use with other sockets or in solder down applications.

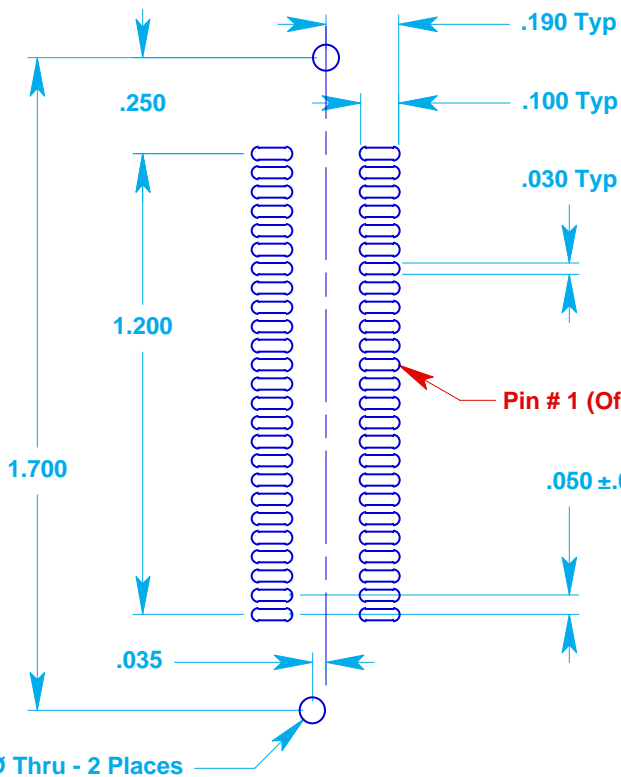

### P C Board Pad Pattern For Mating MERITEC Connector

#### ALPTEX Part #923718-50

(Solder Pads - Near Side)

**ALP  
TEX** Incorporated

P.O. Box 476  
Orwell, Ohio 44076  
(440)437-5570 • (440)437-5571 FAX  
[www.alptex.com](http://www.alptex.com)

ALL STATEMENTS, SPECIFICATIONS AND TECHNICAL INFORMATION ON THIS DATA SHEET ARE SUBJECT TO CHANGE AT ANY TIME WITHOUT NOTICE.

# TSOP FlexProbe

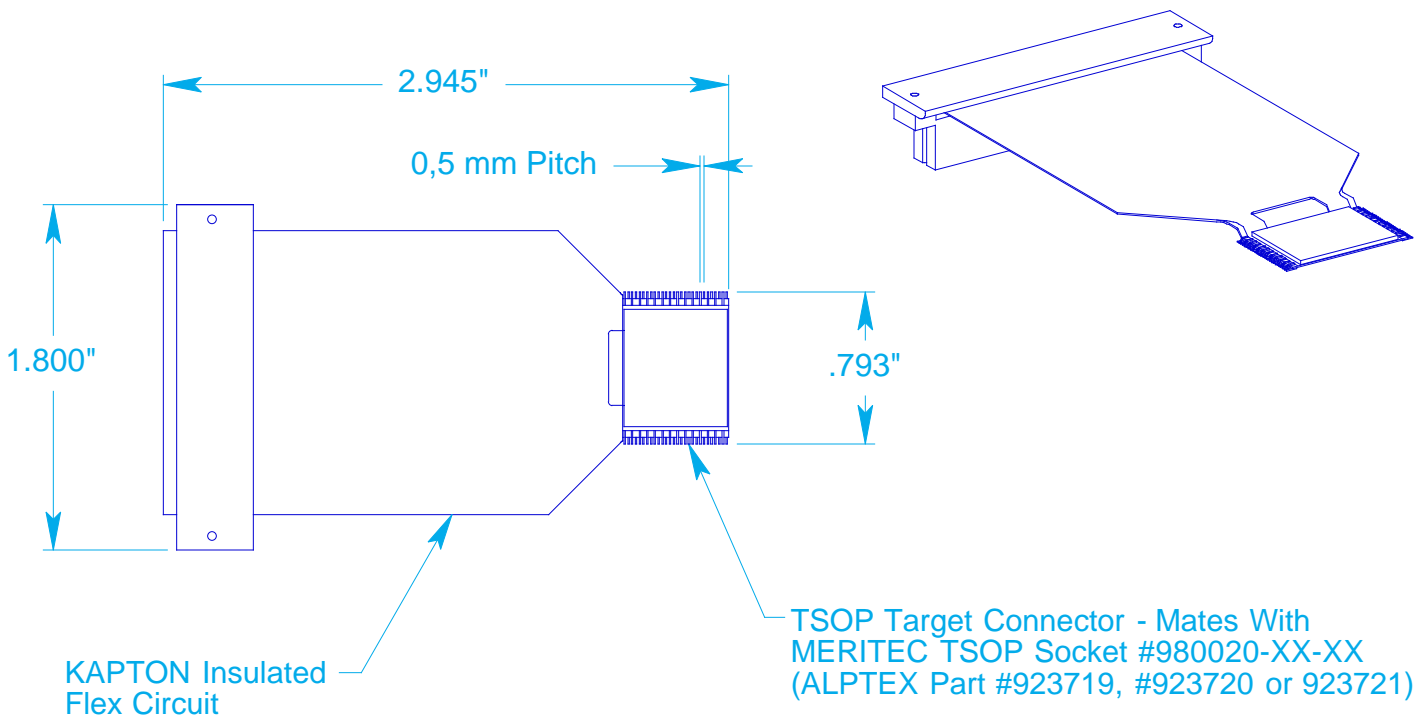

		ALPTEX
PACKAGE	# LEADS	PART NUMBER
TSOP	40	923710-40
	48	923710-48
	56	923710-56

## FEATURES:

- THE MOST FLEXIBLE "TARGET" INTERCONNECT AVAILABLE...MINIMIZES PHYSICAL STRAIN ON THE SOCKET.
- A UNIQUE SOLUTION FOR CONNECTING TO MERITEC TSOP SOCKETS.
- FITS INTO SOCKET LIKE A COMPONENT PACKAGE.
- UTILIZES THE MERITEC SOCKET'S "POSITIVE LOCK" FEATURE TO MAINTAIN A SECURE CONNECTION DURING USE.
- SPRING TEMPER NICKEL-SILVER CONTACTS EXCEED INDUSTRY COMPONENT LEAD REQUIREMENTS.
- COMPACT LENGTH VIRTUALLY ELIMINATES CROSSTALK / EMI PROBLEMS.
- MADE ENTIRELY IN THE U.S.A.
- FLEXPROBES FOR EMULATING OTHER POPULAR COMPONENT PACKAGES ARE ALSO AVAILABLE...CONSULT FACTORY.

**ALPTEX** Incorporated  
 P.O. Box 476  
 Orwell, Ohio 44076  
 (440)437-5570 • (440)437-5571 FAX  
[www.alptex.com](http://www.alptex.com)

ALL STATEMENTS, SPECIFICATIONS AND TECHNICAL INFORMATION ON THIS DATA SHEET ARE SUBJECT TO CHANGE AT ANY TIME WITHOUT NOTICE.

CONTENTS

APP DATA

# TSOP FlexProbe Application Data

ALPTEX Part Number 923710-XX

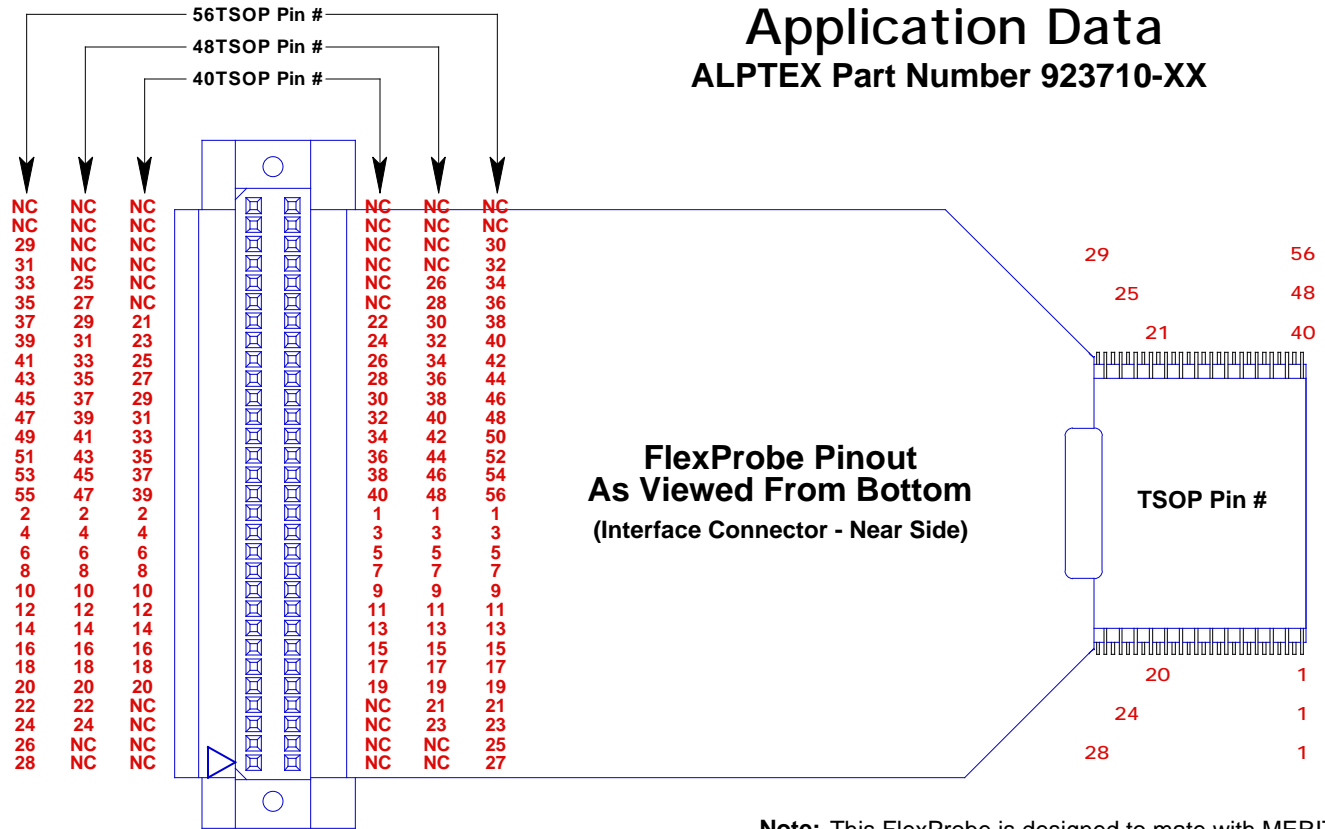

**Note:** This FlexProbe is designed to mate with MERITEC TSOP Socket #980020-XX-XX ONLY. It is not intended for use with other sockets or in solder down applications.

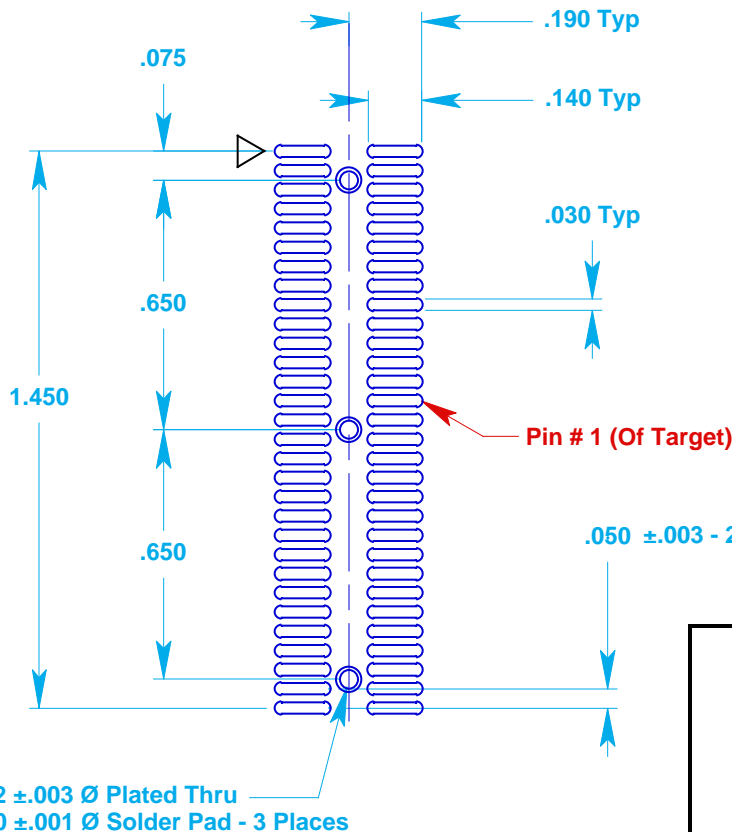

**P C Board Pad Pattern  
For Mating AMP Connector  
AMP #104549-8**  
(Solder Pads - Near Side)

**ALP  
TEX** Incorporated  
P.O. Box 476  
Orwell, Ohio 44076  
(440)437-5570 • (440)437-5571 FAX  
www.alptex.com

ALL STATEMENTS, SPECIFICATIONS AND TECHNICAL INFORMATION ON THIS DATA SHEET ARE SUBJECT TO CHANGE AT ANY TIME WITHOUT NOTICE.



# TSOP FlexProbe (Direct Solder)

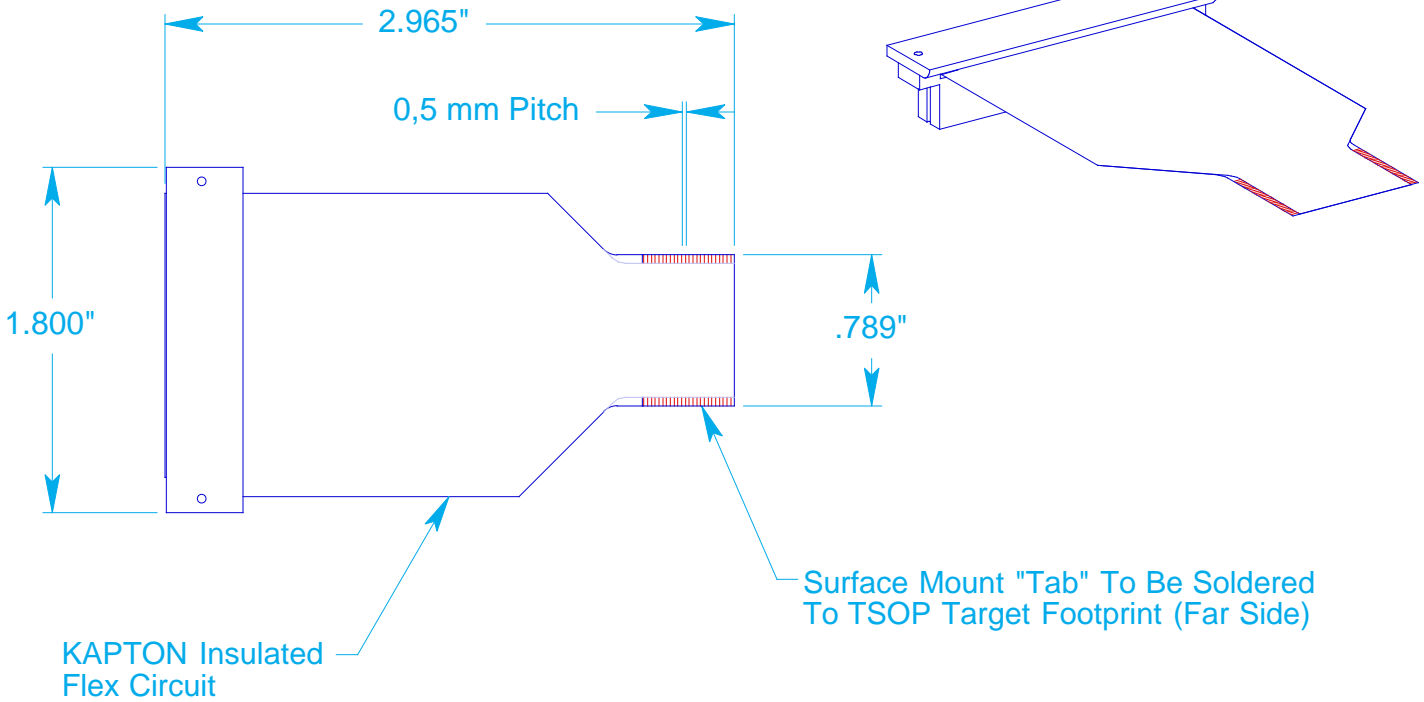

ALPTEX		
PACKAGE	# LEADS	PART NUMBER
TSOP	32	923712-32
	40	923712-40
	48	923712-48
	56	923712-56

## FEATURES:

- THE MOST FLEXIBLE "TARGET" INTERCONNECT AVAILABLE...MINIMIZES PHYSICAL STRAIN ON THE TARGET PADS.
- A UNIQUE SOLUTION FOR CONNECTING DIRECTLY TO YOUR P. C. BOARD.
- REFLOW SOLDERS TO STANDARD TSOP PAD PATTERN.
- ELIMINATES NEED TO ALTER P. C. BOARD BETWEEN DEVELOPMENT AND PRODUCTION PHASES.
- COMPACT LENGTH VIRTUALLY ELIMINATES CROSSTALK / EMI PROBLEMS.
- MADE ENTIRELY IN THE U.S.A.
- FLEXPROBES FOR EMULATING OTHER POPULAR COMPONENT PACKAGES ARE ALSO AVAILABLE...CONSULT FACTORY.

ALL STATEMENTS, SPECIFICATIONS AND TECHNICAL INFORMATION ON THIS DATA SHEET ARE SUBJECT TO CHANGE AT ANY TIME WITHOUT NOTICE.

**ALPTEX** Incorporated  
P.O. Box 476  
Orwell, Ohio 44076  
(440)437-5570 • (440)437-5571 FAX  
[www.alptex.com](http://www.alptex.com)

# TSOP FlexProbe Application Data

ALPTEX Part Number 923712-XX  
(Direct Solder)

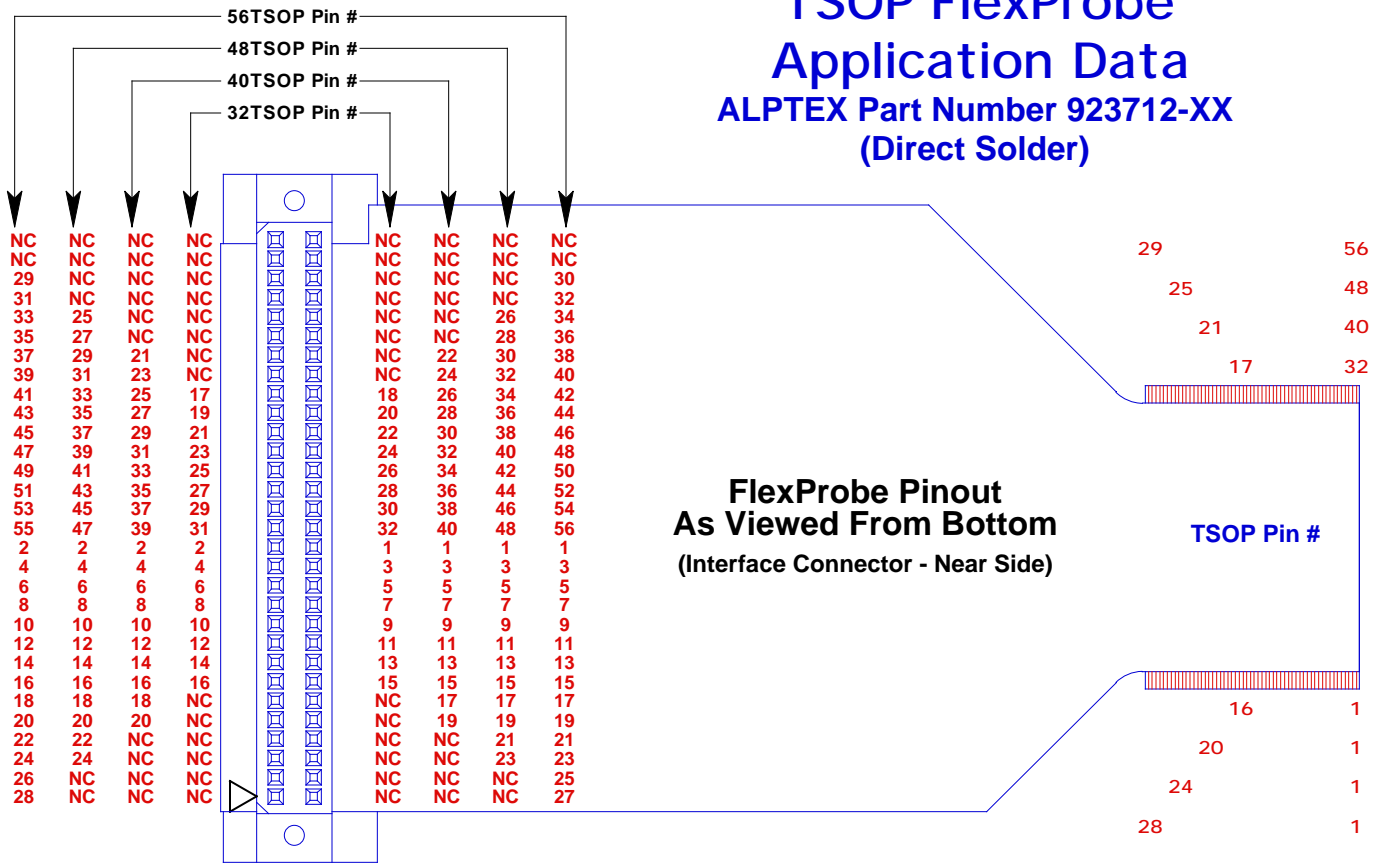

**Note:** This FlexProbe is designed to be reflow soldered directly to the P. C. Board.  
It is not intended for use with sockets.

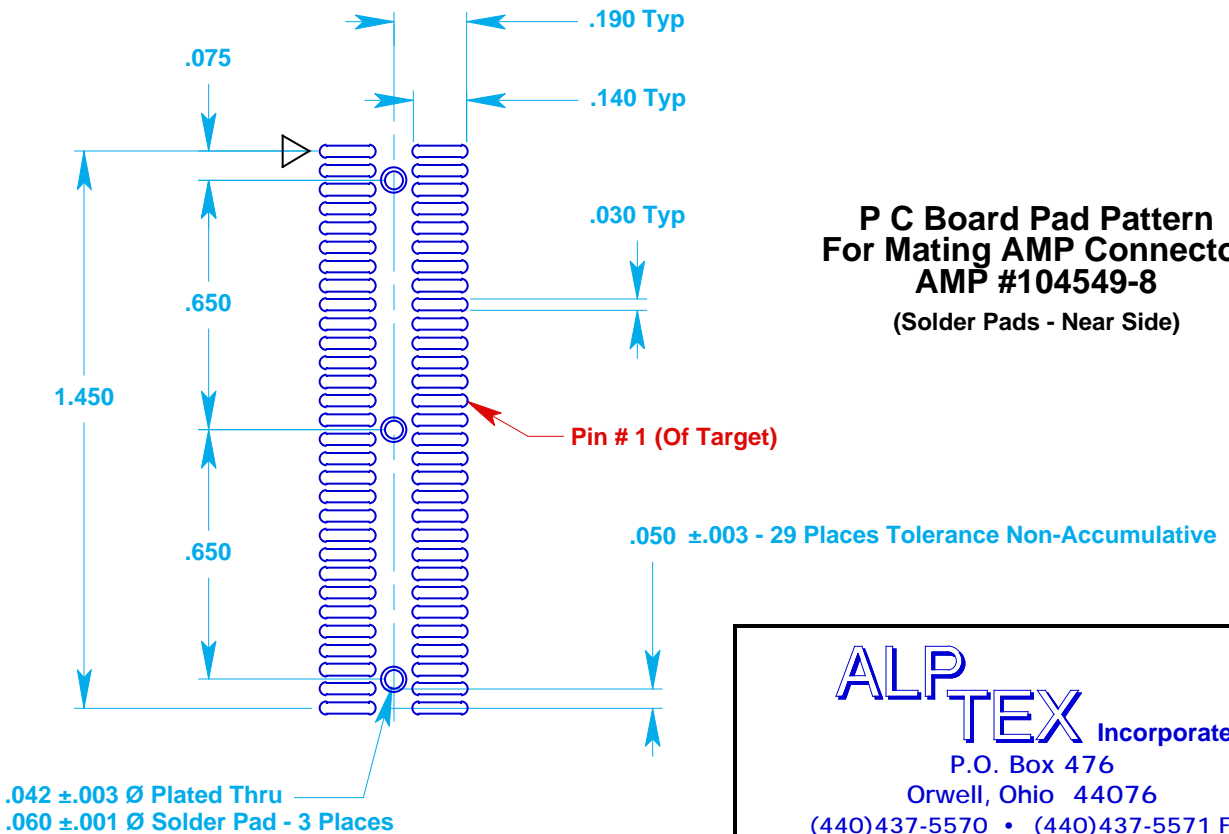

ALL STATEMENTS, SPECIFICATIONS AND TECHNICAL INFORMATION ON THIS DATA SHEET ARE SUBJECT TO CHANGE AT ANY TIME WITHOUT NOTICE.

**ALP  
TEX** Incorporated  
P.O. Box 476  
Orwell, Ohio 44076  
(440)437-5570 • (440)437-5571 FAX  
www.alptex.com

# TSOP FlexProbe (Reverse Pinout)

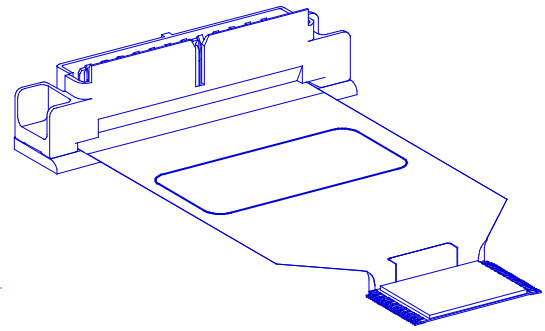
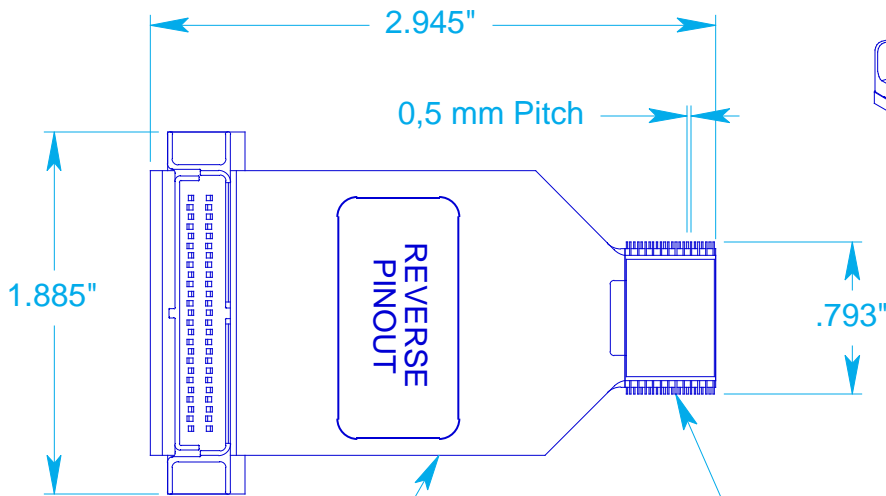

KAPTON Insulated Flex Circuit

TSOP Target Connector - Mates With MERITEC TSOP Socket #980020-XX-XX (ALPTEX Part #923719 or #923720)



50 Position Interface Connector - Mates With MERITEC Surface Mount Hermaphroditic Connector (ALPTEX Part #923718-50)

ALPTEX		
PACKAGE	# LEADS	PART NUMBER
TSOP	40	923723-40
	48	923723-48

## FEATURES:

- THE MOST FLEXIBLE "TARGET" INTERCONNECT AVAILABLE...MINIMIZES PHYSICAL STRAIN ON THE SOCKET.
- A UNIQUE SOLUTION FOR CONNECTING TO MERITEC TSOP SOCKETS.
- ENABLES AN INTERFACE MAPPED FOR THE STANDARD FLEXPROBE (ALPTEX #923707) TO COMMUNICATE CORRECTLY WITH A REVERSE PINOUT TARGET.
- FITS INTO SOCKET LIKE A COMPONENT PACKAGE.
- UTILIZES THE MERITEC SOCKET'S "POSITIVE LOCK" FEATURE TO MAINTAIN A SECURE CONNECTION DURING USE.
- SPRING TEMPER NICKEL-SILVER CONTACTS EXCEED INDUSTRY COMPONENT LEAD REQUIREMENTS.
- COMPACT LENGTH VIRTUALLY ELIMINATES CROSSTALK / EMI PROBLEMS.
- MERITEC HERMAPHRODITIC CONNECTOR PROVIDES A DEPENDABLE AND COMPACT INTERFACE FOR YOUR TEST / EMULATION CIRCUITRY.
- MADE ENTIRELY IN THE U.S.A.
- FLEXPROBES FOR EMULATING OTHER POPULAR COMPONENT PACKAGES ARE ALSO AVAILABLE...CONSULT FACTORY.

**ALPTEX** Incorporated  
 P.O. Box 476  
 Orwell, Ohio 44076  
 (440)437-5570 • (440)437-5571 FAX  
[www.alptex.com](http://www.alptex.com)

ALL STATEMENTS, SPECIFICATIONS AND TECHNICAL INFORMATION ON THIS DATA SHEET ARE SUBJECT TO CHANGE AT ANY TIME WITHOUT NOTICE.

# TSOP FlexProbe Application Data

## ALPTEX Part Number 923723-XX (Reverse Pinout)

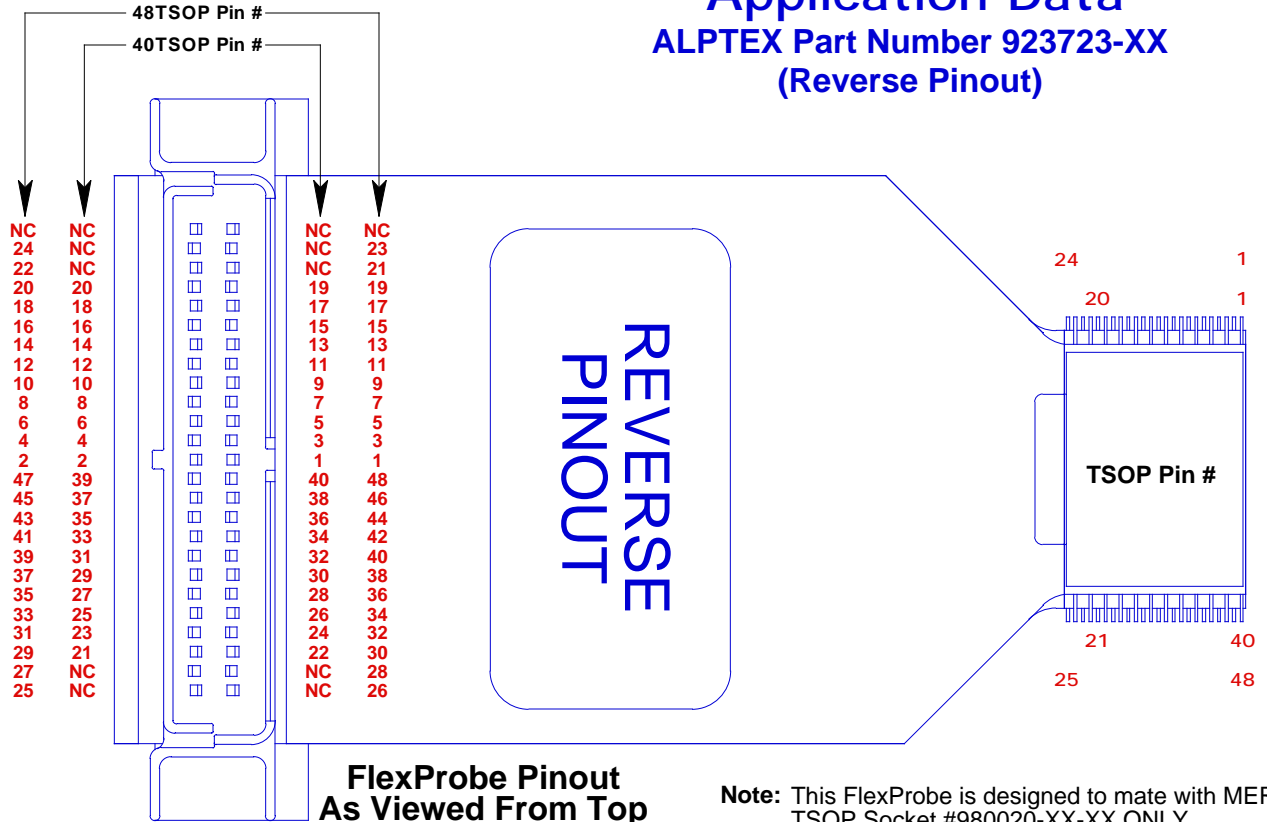

**FlexProbe Pinout  
As Viewed From Top**  
(Interface Connector - Near Side)

**Note:** This FlexProbe is designed to mate with MERITEC TSOP Socket #980020-XX-XX ONLY. It is not intended for use with other sockets or in solder down applications.

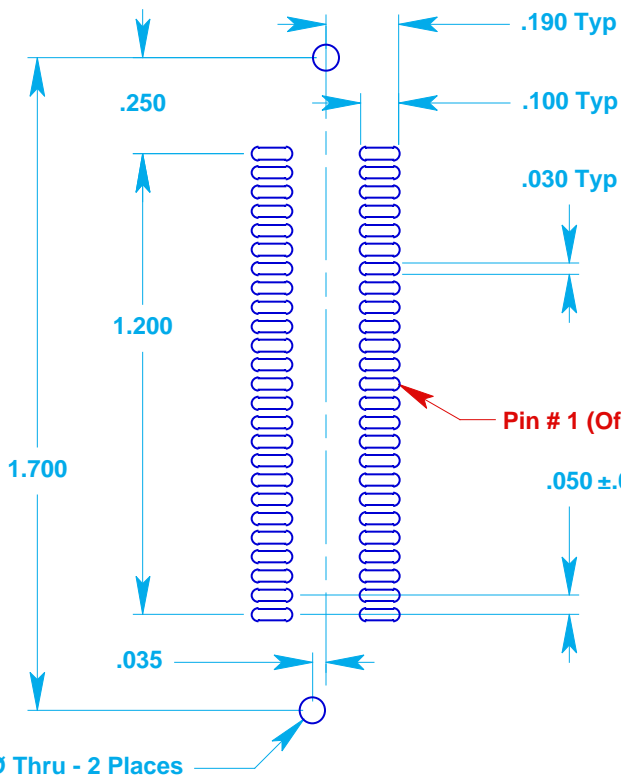

**P C Board Pad Pattern  
For Mating MERITEC Connector**  
**ALPTEX Part #923718-50**  
(Solder Pads - Near Side)

**ALP  
TEX** Incorporated  
P.O. Box 476  
Orwell, Ohio 44076  
(440)437-5570 • (440)437-5571 FAX  
[www.alptex.com](http://www.alptex.com)

ALL STATEMENTS, SPECIFICATIONS AND TECHNICAL INFORMATION ON THIS DATA SHEET ARE SUBJECT TO CHANGE AT ANY TIME WITHOUT NOTICE.

# TSOP FlexProbe (Reverse Pinout)

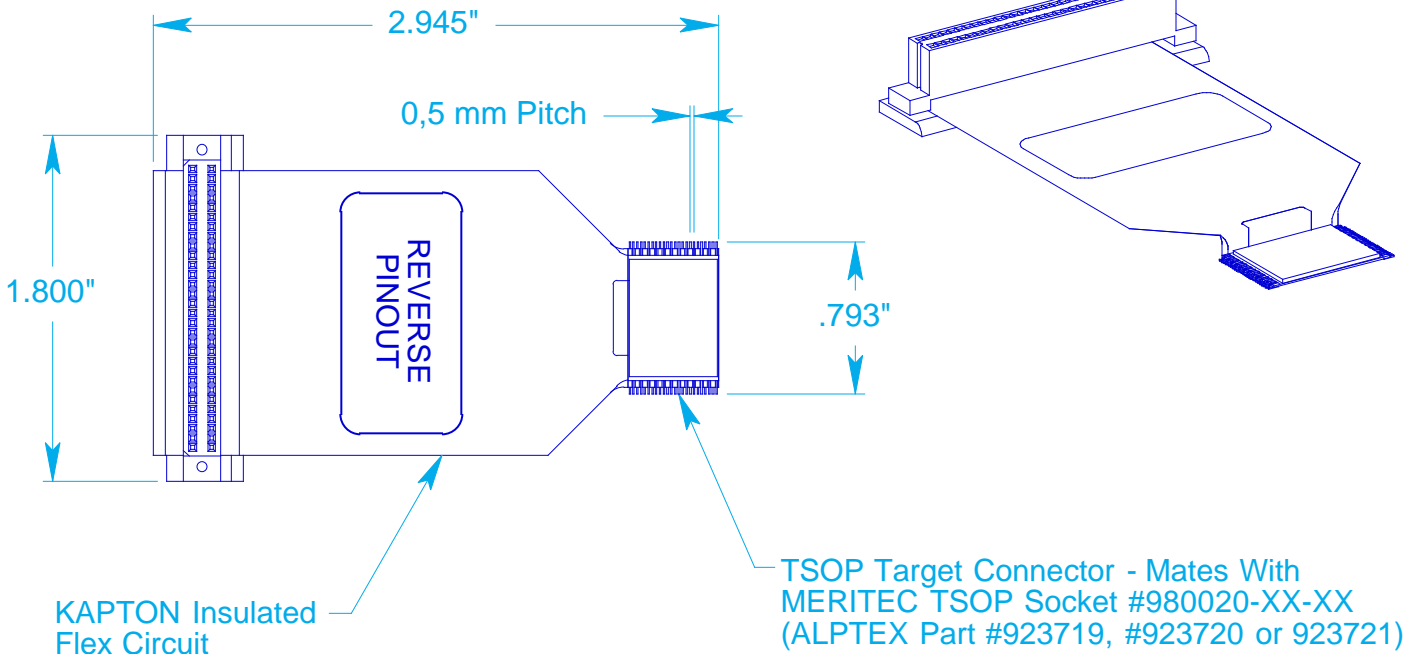

		ALPTX
PACKAGE	# LEADS	PART NUMBER
TSOP	40	923724-40
	48	923724-48
	56	923724-56

## FEATURES:

- THE MOST FLEXIBLE "TARGET" INTERCONNECT AVAILABLE...MINIMIZES PHYSICAL STRAIN ON THE SOCKET.
- A UNIQUE SOLUTION FOR CONNECTING TO MERITEC TSOP SOCKETS.
- ENABLES AN INTERFACE MAPPED FOR THE STANDARD FLEXPBROBE (ALPTX #923710) TO COMMUNICATE CORRECTLY WITH A REVERSE PINOUT TARGET.
- FITS INTO SOCKET LIKE A COMPONENT PACKAGE.
- UTILIZES THE MERITEC SOCKET'S "POSITIVE LOCK" FEATURE TO MAINTAIN A SECURE CONNECTION DURING USE.
- SPRING TEMPER NICKEL-SILVER CONTACTS EXCEED INDUSTRY COMPONENT LEAD REQUIREMENTS.
- COMPACT LENGTH VIRTUALLY ELIMINATES CROSSTALK / EMI PROBLEMS.
- MADE ENTIRELY IN THE U.S.A.
- FLEXPBROBES FOR EMULATING OTHER POPULAR COMPONENT PACKAGES ARE ALSO AVAILABLE...CONSULT FACTORY.

**ALPTX**  
**TEX** Incorporated  
 P.O. Box 476  
 Orwell, Ohio 44076  
 (440)437-5570 • (440)437-5571 FAX  
[www.alptex.com](http://www.alptex.com)

ALL STATEMENTS, SPECIFICATIONS AND TECHNICAL INFORMATION ON THIS DATA SHEET ARE SUBJECT TO CHANGE AT ANY TIME WITHOUT NOTICE.

# TSOP FlexProbe Application Data

ALPTEx Part Number 923724-XX  
(Reverse Pinout)

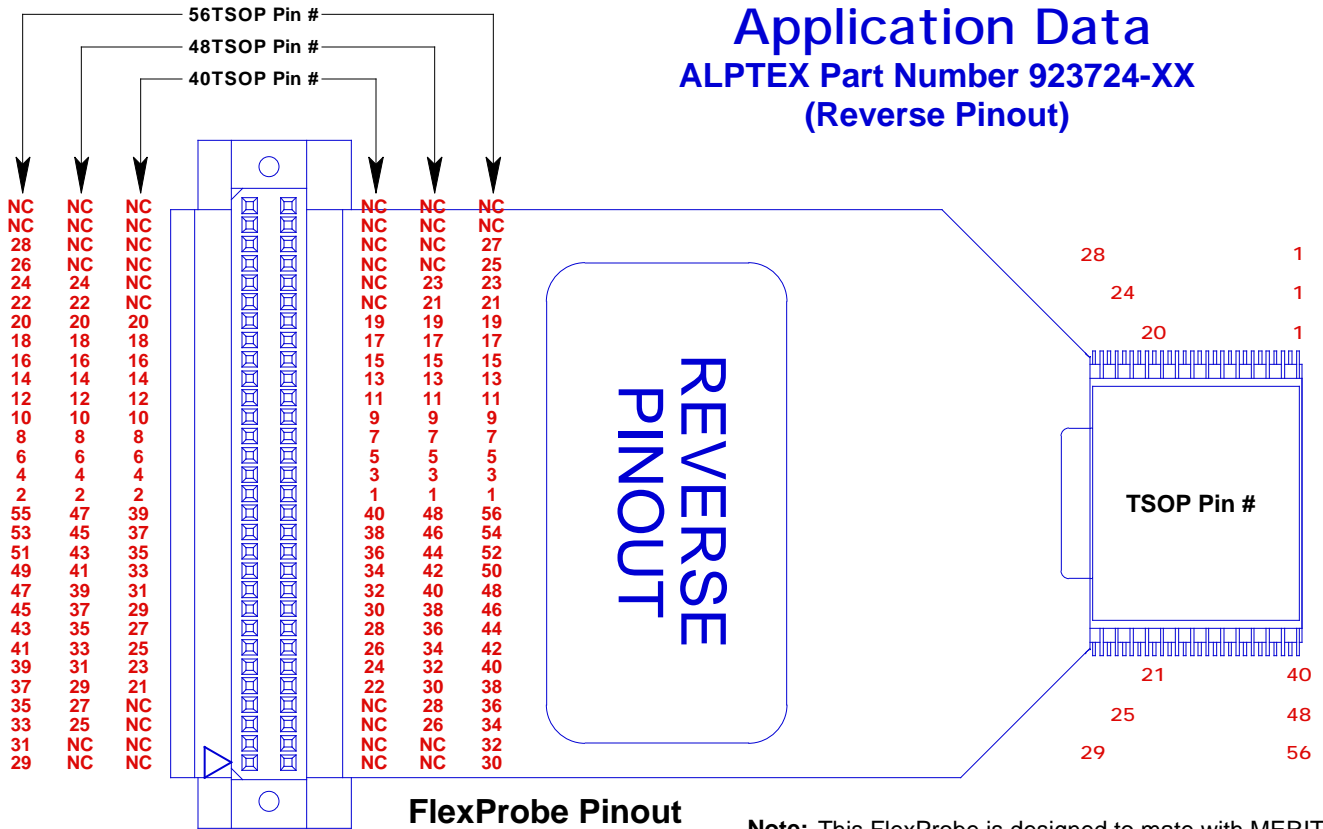

**FlexProbe Pinout  
As Viewed From Top**  
(Interface Connector - Near Side)

**Note:** This FlexProbe is designed to mate with MERITEC TSOP Socket #980020-XX-XX ONLY. It is not intended for use with other sockets or in solder down applications.

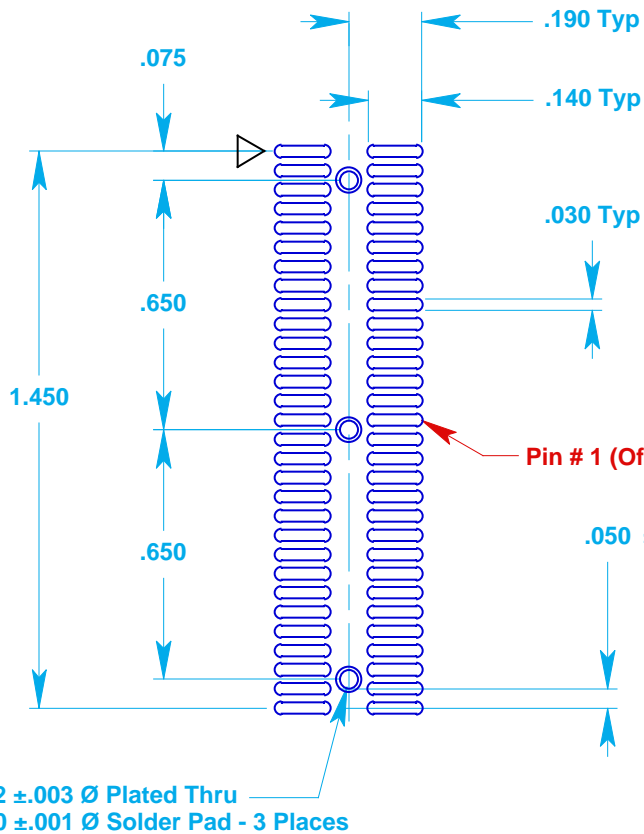

**P C Board Pad Pattern  
For Mating AMP Connector  
AMP #104549-8**  
(Solder Pads - Near Side)

**ALPTEx** Incorporated  
P.O. Box 476  
Orwell, Ohio 44076  
(440)437-5570 • (440)437-5571 FAX  
www.alptex.com

ALL STATEMENTS, SPECIFICATIONS AND TECHNICAL INFORMATION ON THIS DATA SHEET ARE SUBJECT TO CHANGE AT ANY TIME WITHOUT NOTICE.